

Installation Instructions

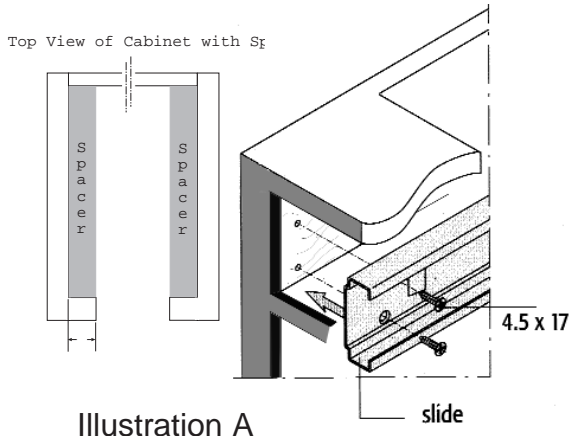

**FOR FRAME CABINET APPLICATIONS
FOLLOW STEPS 1-2-3-4, ETC.**

STEP 1

Cut (2) wood spacers 3" tall X thickness equal to distance from inside of end panel to flush with inside of face frame. (Illustration A)

STEP 2

Fasten spacers to end panels. Bottom of spacers should be even with bottom of drawer opening. Drill (2) 1/8" pilot holes 5/8" deep centered 1 15/16" above bottom of drawer opening. Front hole should be 1 3/8" behind front of face frame. Back hole should be 16 3/8" on center from front hole. (Illustration B)

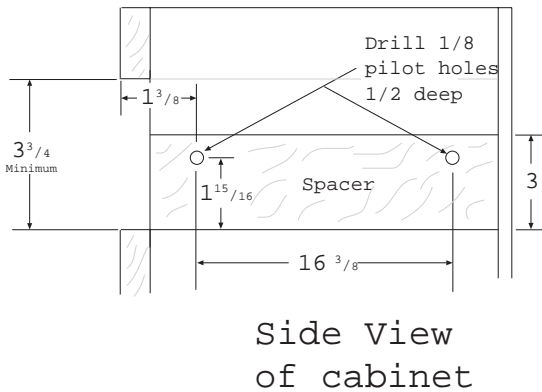

Illustration B

STEP 3

Mount right & left slide assemblies to spacers using top mounting holes with 4mm x 1/2" Euro screws.

**FOR FRAMELESS CABINET APPLICATIONS
MOUNT SLIDE ASSEMBLIES DIRECTLY TO
LEFT AND RIGHT CABINET WALLS AND
CONTINUE WITH STEP 4**

STEP 4

Place ironing board assembly on slide support brackets and center in opening. Install 1/4" x 1/2" socket head cap screws in rear brackets. (Place washer on both top & bottom.) (Illustration C)

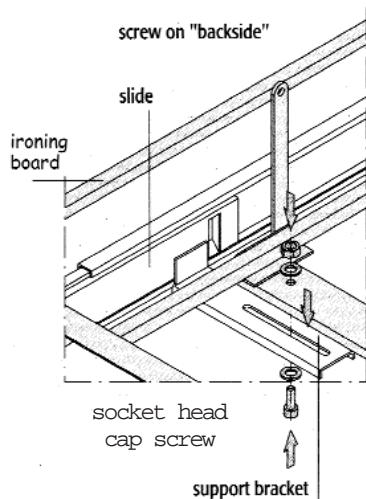

Illustration C

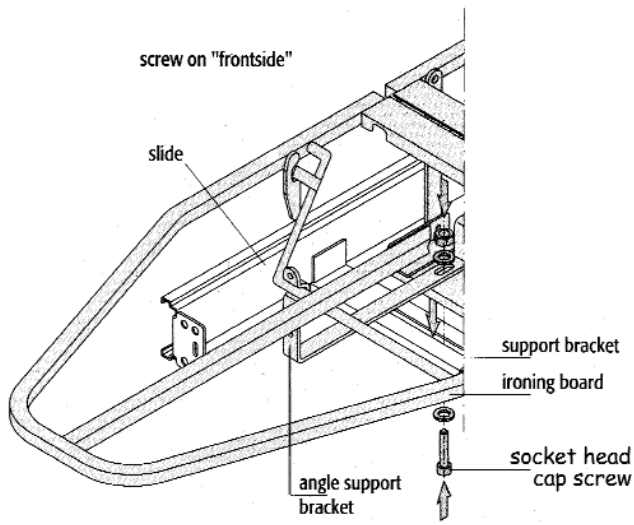

Illustration D

STEP 5

Install angle support brackets on top of front slide. Support bracket and base bracket using 1/4" x 5/8" socket head cap screws. (Place washer on both top & bottom.) Do not tighten bolts at this time. (Illustration D)

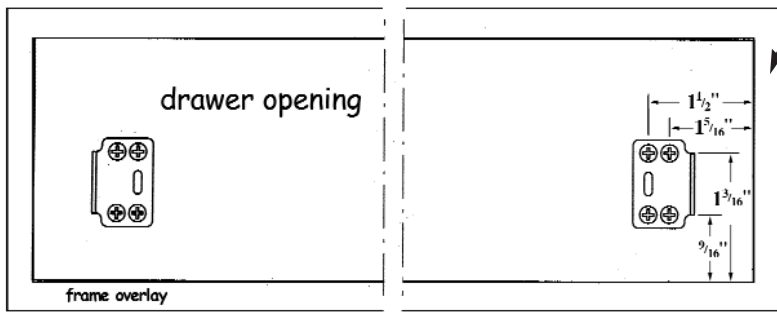

Illustration E

STEP 6 : FRONT MOUNTING

Drill 1/8" pilot holes 5/8" deep in drawer front. (Illustration E)

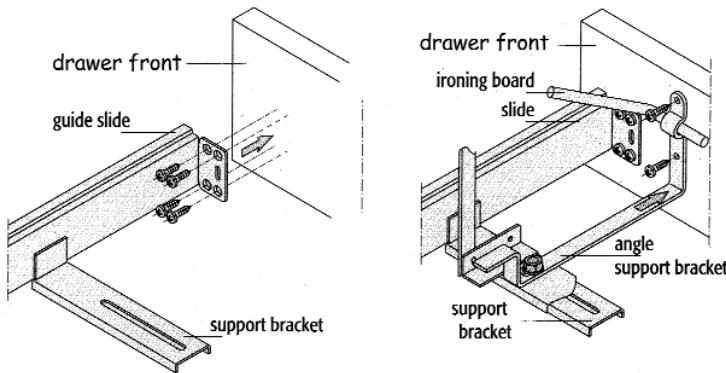

Illustration F

STEP 7

Mount drawer front (using 4mm X 1/2" Euro screws) and angle support bracket (using # 8 x 5/8" wood screws.) After slide & angle supports are installed, tighten cap screws holding slide support, ironing board base, and angle support together. (Illustration F)



2409 Plantside Dr. • Jeffersontown, KY 40299
800-626-1126 • 502-499-5835 • FAX: 502-491-2215

We hope you enjoy your fold-out ironing board! For customer assistance, please contact our customer service specialists at the number below