

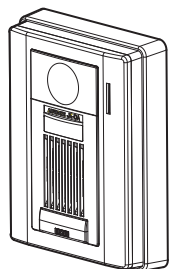

# JK-DA, JK-DV, JK-DVF

VIDEO DOOR STATION  
 POSTE DE PORTE VIDÉO  
 VIDEO PORTERO  
 VIDEODEURPOST

POSTAZIONE VIDEOCITOFONICA ESTERNA



## JK-DA

*Video door station  
 Poste de porte vidéo  
 Video portero  
 Videodeurpost met kunststof  
 opbouwbehuizing  
 Postazione videocitofonica  
 esterna*



## JK-DVF

*Vandal-resistant video door station  
 Portier vidéo résistant au vandalisme  
 Video portero antivandálico  
 Videodeurpost met inox antivandalisme-  
 inbouwbehuizing  
 Postazione videocitofonica esterna  
 resistente agli atti vandalici*

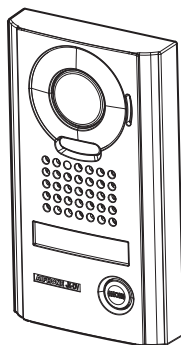

## JK-DV

*Vandal-resistant video door station  
 Portier vidéo résistant au vandalisme  
 Video portero antivandálico  
 Videodeurpost met metalen  
 antivandalisme-opbehuizing  
 Postazione videocitofonica esterna  
 resistente agli atti vandalici*

INSTALLATION MANUAL  
 MANUEL D'INSTALLATION  
 MANUAL DE INSTALACIÓN  
 INSTALLATIEHANDLEIDING  
 MANUALE D'INSTALLAZIONE

# PRECAUTIONS

-  General Prohibitions
  Prohibition to Dismantle the Unit
  Prohibition on Subjecting the Unit to Water
  General Precautions

## ⚠ WARNING

(Negligence could result in death or serious injury.)

- Ⓜ 1. Do not dismantle or alter the unit. Fire or electric shock could result.
- ⚠ 2. Existing wiring such as chime wiring, etc. may contain high voltage AC electricity. Damage to the unit or electric shock could result. Wiring and installation should be done by a qualified technician.
- Ⓜ 3. This unit is not an explosion-proof unit. Do not install or use the unit in locations that are filled with flammable gas such as oxygen rooms. Fire or an explosion could result.

## ⚠ CAUTION







(Negligence could result in injury to people or damage to property.)

- ⚠ 1. Before turning on power, make sure wires are not crossed or shorted. If not, fire or electric shock could result.
- Ⓜ 2. Do not install or make any wire terminations while power supply is plugged in. It can cause electrical shock or damage to the unit.

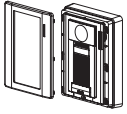
## General Precautions

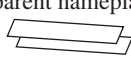
1. The door station is weather resistant, but do not spray high pressure water on door station directly. Unit trouble could result.

## 1 PACKAGE CONTENTS

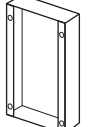
 JK-DA Front panel Main unit	 Mounting screws (Mounting screws x 2 Wood mounting screws x 2)	 Special screwdriver   Transparent nameplates x 2	INSTALLATION MANUAL  
 JK-DV	 Mounting screws (x4) and anchor bolts (x4)		
 JK-DVF	 Special screws (x4) Flush mount back box		

## 2 INSTALLATION

### 2-1 Mounting locations

"Do not install video door station in any of the following locations where lighting or the ambient environment could impact the display on the video monitor due to the characteristics of the door station's camera."

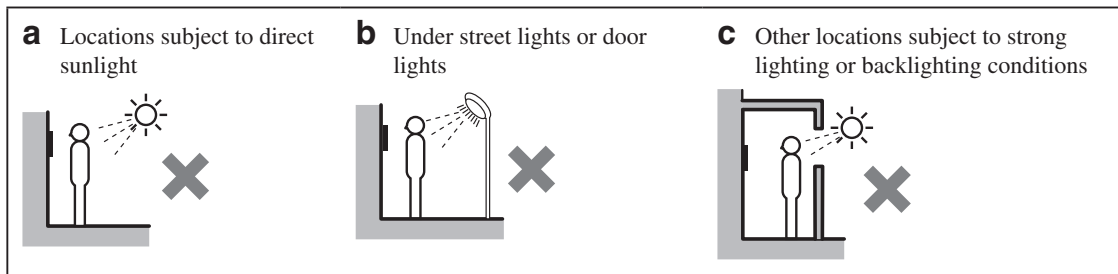

## 2-2 Mounting positions and image view area

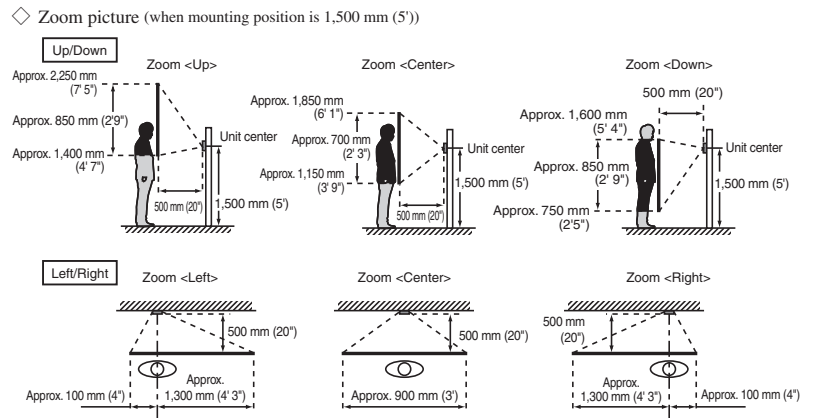
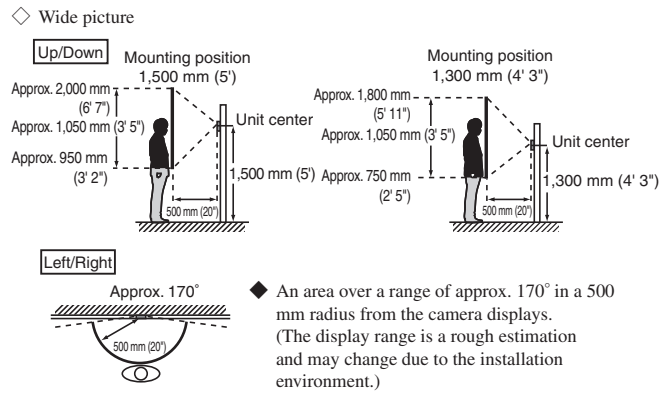
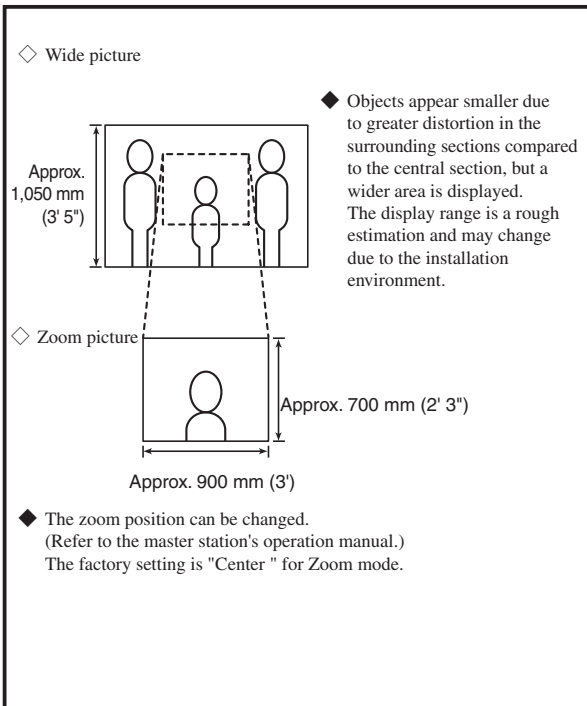

## 2-3 Cable

- 1 PVC jacket with PE (polyethylene) insulated cable is recommended.



- 2 Never use individual conductors, twisted pair cable or coaxial cable.

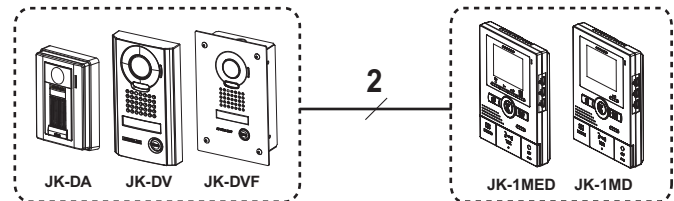
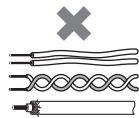

## 2-4 Wiring distance

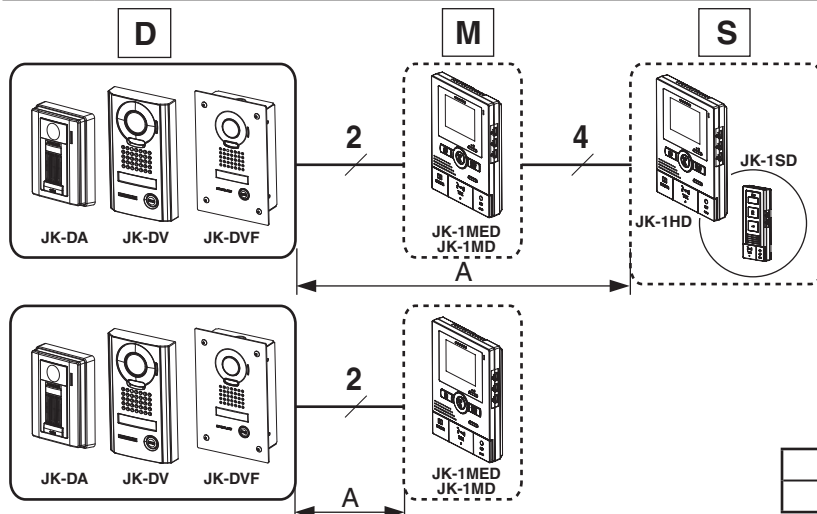

	Ø 0.65 mm	22 AWG	Ø 1.0 mm	18 AWG
A	50 m	165'	100 m	330'

# 3 MOUNTING

English

## JK-DA

### ① Removing the main unit from the mounting frame

Remove the main unit. (Loosen the locking screws.)

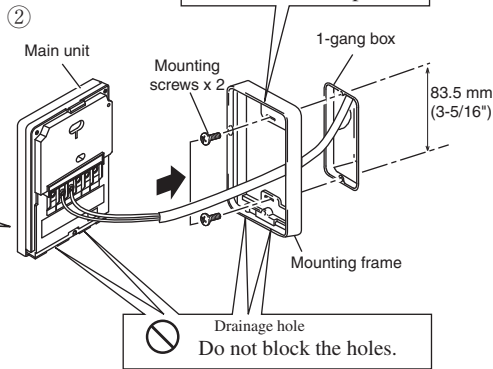
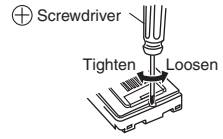

### ③ Mount the main unit on the mounting frame, and fit the front panel on.

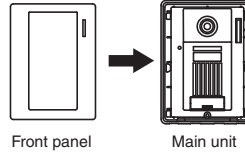

### Removing the front panel

<Bottom surface>



Pry off the front panel with a flathead screwdriver.

## JK-DV

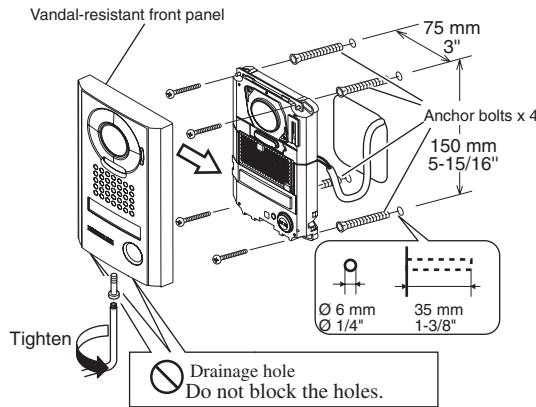
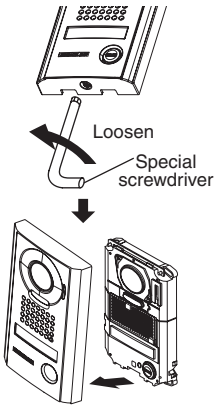

### Using the transparent nameplates

#### Inserting the transparent nameplates

- ① Remove the vandal-resistant front panel.
- ② Peel off the protective seals on the plate (both sides).
- ③ Fill in the name of the resident on the transparent nameplate.
  - ⚠ Be sure to leave 25 mm (1") of white space on the left end to account for insertion.
- ④ Insert the filled-in transparent nameplate at the specified insertion opening (indicated with ⇨ in diagram).

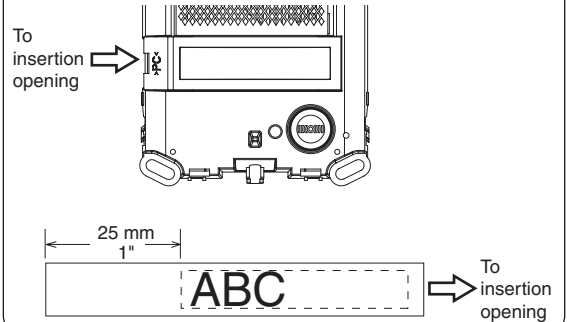

## JK-DVF

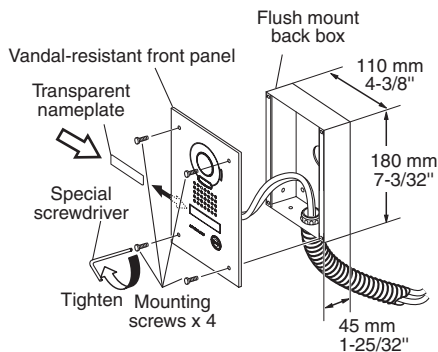

### Using the transparent nameplates

#### Inserting the transparent nameplates

- ① Remove the vandal-resistant front panel from the flush mount back box.
- ② Peel off the protective seals on the plate (both sides).
- ③ Fill in the name of the resident on the transparent nameplate.
  - ⚠ Be sure to leave 25 mm (1") of white space on the left end to account for insertion.
- ④ Insert the filled-in transparent nameplate at the specified insertion opening on the rear side of the vandal-resistant front panel (indicated with ⇨ in diagram).



## 4 WIRING

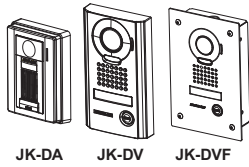

JK-DA JK-DV JK-DVF

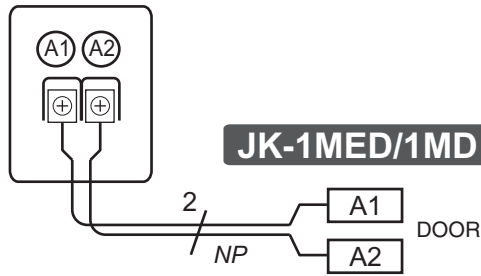

NP: Non-polarized

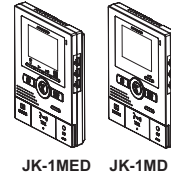

JK-1MED JK-1MD

## 5 TECHNICAL PRECAUTIONS

### Technical precautions

- Operating temperature: -10 °C to +60 °C (+14 °F to +140 °F)
- Cleaning: Clean the units with a soft cloth dampened with a neutral household cleanser. Do not use any abrasive cleaner or cloth.
- Door station is weather resistant. However, do not spray high pressure water on door station directly. Unit trouble could result.

## 6 SPECIFICATIONS

- Camera unit: Complementary metal oxide semiconductor (CMOS)
  - Scanning lines: 525 lines
  - Minimum subject illumination: 5 Lux at 50 cm (1'6") distance
  - Dimensions:
- |                                   |   |                                   |                           |
|-----------------------------------|---|-----------------------------------|---------------------------|
| JK-DA:                            | 129 (H) x 97 (W) x 35.5 (D) (mm)<br>5-1/8 (H) x 3-7/8 (W) x 1-7/16 (D) (inches)           | • Weight:                         |                           |
| JK-DV:                            | 173 (H) x 98 (W) x 29.5 (D) (mm)<br>6-13/16 (H) x 3-7/8 (W) x 1 (D) (inches)              | JK-DA:                            | Approx. 190 g (0.42 lbs.) |
| JK-DVF:                           | 209 (H) x 135 (W) x exposed area 8 (D) (mm)<br>8-1/4 (H) x 5-5/16 (W) x 5/16 (D) (inches) | JK-DV:                            | Approx. 650 g (1.43 lbs.) |
| Flush mount back box:<br>(JK-DVF) | 180 (H) x 110 (W) x 45 (D) (mm)<br>7-3/32 (H) X 4-3/8 (W) X 1-25/32 (D) (inches)          | JK-DVF:                           | Approx. 580 g (1.27 lbs.) |
|                                   |   | Flush mount back box:<br>(JK-DVF) | Approx. 450 g (1.0 lbs.)  |

## Warranty

English

Aiphone warrants that its products have no material or workmanship defects under normal use conditions for two years after delivery to the end user. Aiphone will perform repair or replacement free of charge if the product is defective and the warranty applies to the defect. Aiphone reserves unto itself the sole right to make the final decision whether there is a defect in materials and/or workmanship and whether or not the product is under warranty. This warranty shall not apply to any Aiphone product which has been subject to misuse, neglect, accident, or to use in violation of instructions furnished, nor extended to units which have been repaired or altered outside of the factory. This warranty does not cover batteries or damage caused by batteries used in connection with the unit. This warranty only includes carry-in repairs. Any repairs must be made at the shop or place designated in writing by Aiphone. Aiphone will not be responsible for any costs incurred during on-site service calls. Aiphone will not provide compensation for any loss or damage incurred by the breakdown or malfunction of its products during use, or for any consequent inconvenience or losses that may result.

The object area of  is the EU.

## Garantie

Français

Aiphone garantit que ce produit ne présente pas de défaut matériel ou de fabrication dans des conditions normales d'utilisation pendant les deux années suivant la livraison à l'utilisateur final. Aiphone en effectuera gratuitement la réparation ou le remplacement si le produit est défectueux et que la garantie s'applique pour le défaut. Aiphone se réserve le droit exclusif de décider s'il existe ou non un défaut de matière ou de fabrication et si l'appareil est ou non couvert par la garantie. Cette garantie ne s'applique pas à tout produit Aiphone qui a été l'objet d'une utilisation impropre, de négligence, d'un accident ou qui a été utilisé en dépit des instructions fournies; elle ne couvre pas non plus les appareils qui ont été réparés ou modifiés en dehors de l'usine. Cette garantie ne couvre pas les piles ni les dégâts infligés par les piles utilisées dans l'appareil. Cette garantie comprend uniquement les réparations en atelier. Toutes les réparations doivent être réalisées à l'atelier ou au site désigné par écrit par Aiphone. Aiphone décline toute responsabilité en cas de frais encourus pour les dépannages à domicile. Aiphone n'indemniserà pas le client en cas de pertes, de dommages ou de désagréments causés par une panne ou un dysfonctionnement d'un de ses produits.

La zone d'application de  est l'UE.

## Garantía

Español

Aiphone garantiza que sus productos no tienen defectos de material ni de mano de obra bajo condiciones de uso normal durante dos años tras su entrega al usuario final. Aiphone realizará la reparación o cambio libre de costo si el producto está defectuoso y la garantía se aplica al defecto. AIPHONE se reserva el derecho de tomar la decisión final de si hay o no defectos de material y/o de mano de obra, y de si el producto está o no cubierto por la garantía. Esta garantía no cubre ningún producto AIPHONE que haya sido mal utilizado, descuidado, accidentado, o empleado violando las instrucciones suministradas; la garantía tampoco se aplica a unidades que hayan sido reparadas o alteradas por personas fuera de la fábrica. Esta garantía no cubre las pilas ni los daños causados por pilas utilizadas asociadas a la unidad. Esta garantía sólo incluye reparaciones acarreadas por el cliente. Todas las reparaciones deben realizarse en el taller o lugar que Aiphone designe por escrito. Aiphone no se responsabilizará de los gastos generados durante llamadas de servicio. Aiphone no indemnizará por ninguna pérdida o daño en que se incurra debido a la avería o falla de sus productos durante su uso, ni por ningún inconveniente o pérdida que se produzca como consecuencia.

El área del objeto  es la EU.

## Garantie

Nederlands

Aiphone garandeert dat zijn producten onder normale gebruiksomstandigheden gedurende twee jaar na levering aan de eindgebruiker vrij zijn van materiaal- of fabricagefouten. Aiphone zal het product kosteloos herstellen of vervangen als het defect is en de garantie van toepassing is op het defect. Aiphone behoudt zich het recht voor om als enige definitief te bepalen of er al dan niet sprake is van een materiaal- en/of fabricagefout; en of het product nog onder garantie is. Deze garantie geldt niet voor een Aiphone-product dat is blootgesteld aan verkeerd gebruik, verwaarlozing, een ongeval of verkeerde bediening en evenmin voor toestellen die buiten de fabriek zijn hersteld of gewijzigd. Deze garantie geldt niet voor batterijen of schade veroorzaakt door batterijen die in het toestel zijn gebruikt. Deze garantie geldt uitsluitend voor herstellingen die worden ingeleverd en opgehaald door de klant. Alle herstellingen moeten worden uitgevoerd in de winkel of op de plaats die schriftelijk is aangeduid door Aiphone. Kosten die gepaard gaan met herstellingen ter plaatse kunnen niet worden verhaald op Aiphone. Er kan geen schadeloosstelling van Aiphone worden geëist voor enig verlies of schade als gevolg van een defect of storing tijdens het gebruik van zijn producten, of voor enig ongemak of verlies dat hieruit voortvloeit.

Het toepassingsgebied van  is de EU.

## Garanzia

Italiano

La Aiphone garantisce che i suoi prodotti saranno privi di difetti nei materiali o nella lavorazione, in condizioni di utilizzo normali, per un periodo di due anni dalla consegna all'utente finale. La Aiphone eseguirà la riparazione o la sostituzione gratuita del prodotto qualora tale prodotto debba risultare difettoso e la garanzia sia applicabile al difetto rilevato. La Aiphone si riserva il diritto esclusivo di stabilire in via definitiva se sono presenti difetti nei materiali e/o nella lavorazione e se il prodotto è coperto dalla garanzia oppure no. La presente garanzia non è applicabile ad alcun prodotto Aiphone che sia stato sottoposto ad uso improprio, negligenza, incidente, o che sia stato utilizzato in violazione alle istruzioni fornite, né può essere estesa alle unità che sono state riparate o manomesse al di fuori della fabbrica. Questa garanzia non copre le batterie né i danni causati dalle batterie usate in connessione con l'unità. Questa garanzia copre solo le riparazioni del prodotto consegnato presso il punto designato. Le eventuali riparazioni devono essere eseguite presso l'officina o il luogo designato per iscritto dalla Aiphone. La Aiphone non potrà essere ritenuta responsabile di eventuali costi sostenuti in caso di chiamata per l'assistenza sul posto. La Aiphone non offrirà alcun compenso per gli eventuali danni o perdite subiti a causa della rottura o del guasto dei suoi prodotti durante l'uso, o per qualsiasi disagio o perdita conseguente che si dovesse verificare.

L'area oggetto del  è l'UE.

This equipment has been tested and found to comply with the limits for a Class B digital device, pursuant to Part 15 of the FCC Rules. These limits are designed to provide reasonable protection against harmful interference in a residential installation. This equipment generates, uses, and can radiate radio frequency energy, and if not installed and used in accordance with the instructions, may cause harmful interference to radio communications. However, there is no guarantee that interference will not occur in a particular installation. If this equipment does cause harmful interference to radio or television reception, which can be determined by turning the equipment off and on, the user is encouraged to try to correct the interference by one or more of the following measures:

- Reorient or relocate the receiving antenna
- Connect the equipment into an outlet on a circuit different from that to which the receiver is connected.
- Increase the separation between the equipment and receiver.
- Consult the dealer or an experienced radio/TV technician for help.

